

GEO-STAB® - THE FASTEST WAY TO INSTALL HEAT PUMP LOOPS WITHOUT FAIL

The GEO-Stab® fitting provides a reliable, productive, and efficient approach to loop installation for the geothermal heat pump industry. The GEO-Stab® fitting system incorporates an advanced and proven fusionless technology, fully engineered for geothermal heat pump applications. This system is designed to greatly reduce installation time at the job site and the GEO-Stab® fitting joints are designed to be stronger than the pipe itself!

A NEW SYSTEM FOR A PROVEN APPLICATION

The GEO-Stab® fitting features an INTERNAL SEAL and is an all plastic fitting that contains no metal parts.

THE GEO-STAB® IS A COST EFFECTIVE JOINING METHOD

There is no additional assemble equipment required for installation - just chamfer the polyethylene pipe and stab. That's all there is to it! The GEO-Stab's uni-body design eliminates all external parts. The result is a continuous external HDPE body construction that provides for continuity of material throughout the ground loop system. This simplistic design has been pressure rated to 160 psi and results in a joint that is stronger than the pipe itself.

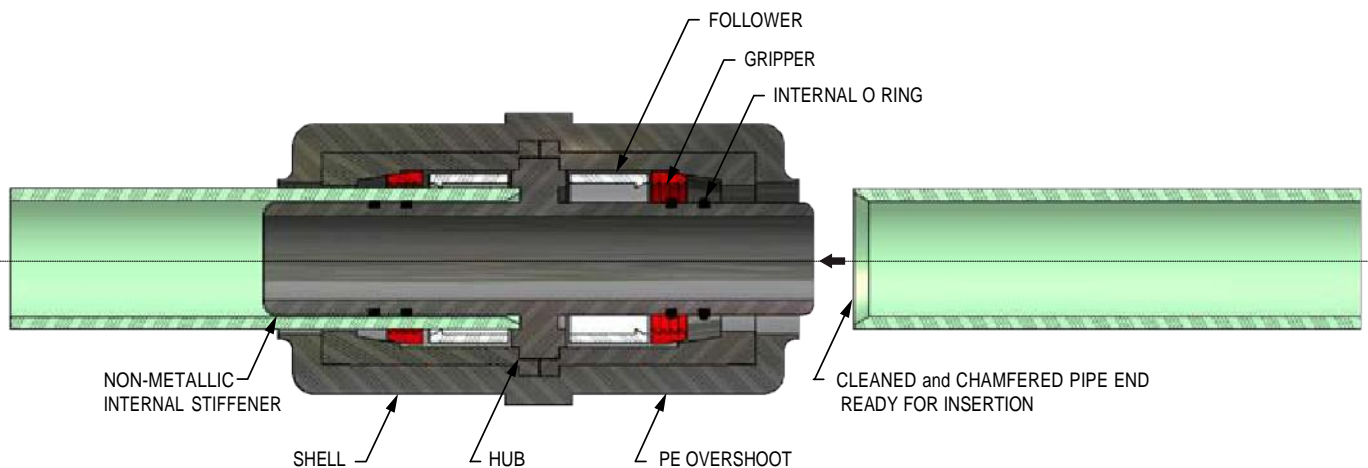

For Details about 50 Year Limited Warranty, Contact Continental.

GEO-STAB® FULL COUPLING

PART #	SIZE	PKGD.
P000-01-0077-54	3/4" IPS DR 11	10
P000-01-0077-55	1" IPS DR 11	10
P000-01-0077-56	1 1/4" IPS DR 11	10
P000-01-0077-57	1 1/2" IPS DR 11	10
P000-01-0077-58	2" IPS DR 11	10



GEO-STAB® END CAP

PART #	SIZE	PKGD.
P000-01-0077-33	3/4" IPS DR 11	10
P000-01-0077-34	1" IPS DR 11	10
P000-01-0077-30	1 1/4" IPS DR 11	10
P000-01-0077-31	1 1/2" IPS DR 11	10
P000-01-0077-32	2" IPS DR 11	10



GEO-STAB® HALF COUPLING X FOR SOCKET FUSION

PART #	SIZE	PKGD.
P000-01-0077-25	3/4" IPS DR 11 X 3/4" IPS SOCKET FUSION	10
P000-01-0077-26	1" IPS DR 11 X 1" IPS SOCKET FUSION	10
P000-01-0077-27	1 1/4" IPS DR 11 X 1 1/4" IPS SOCKET FUSION	10
P000-01-0077-28	1 1/2" IPS DR 11 X 1 1/2" IPS SOCKET FUSION	10
P000-01-0077-29	2" IPS DR 11 X 2" IPS SOCKET FUSION	10



GEO-STAB® 90 DEGREE ELBOW

PART #	SIZE	PKGD.
P000-01-0077-73	3/4" IPS DR 11	10
P000-01-0077-74	1" IPS DR 11	10
P000-01-0077-75	1 1/4" IPS DR 11	10
P000-01-0077-20	1 1/2" IPS DR-11	10
P000-01-0077-21	2" IPS DR-11	10



GEO-STAB® STRAIGHT TEES

PART #	SIZE	PKGD.
P000-01-0077-79	3/4" IPS DR 11	10
P000-01-0077-80	1" IPS DR 11	10
P000-01-0077-81	1 1/4" IPS DR 11	10
P000-01-0077-22	1 1/2" IPS DR 11	10
P000-01-0077-23	2" IPS DR 11	10



GEO-STAB® SCOPE

PART #	SIZE	PKGD.
P000-01-0077-44	3/4" IPS DR 11	10
P000-01-0077-45	1" IPS DR 11	10
P000-01-0077-46	1 1/4" IPS DR 11	10
P000-01-0077-47	1 1/2" IPS DR 11	10
P000-01-0077-48	2" IPS DR 11	10



GEO-STAB® FEMALE THREADED TEES

PART #	SIZE	PKGD.
P000-01-0077-88	3/4" IPS DR 11 X 3/4" IPS DR 11 X 1/2" FPT	10
P000-01-0077-89	1" IPS DR 11 X 1" IPS DR 11 X 1/2" FPT	10



GEO-STAB® REDUCER COUPLINGS

PART#	SIZE	PKGD.
P000-01-0077-35	1" IPS DR 11 X 3/4" IPS DR 11	10
P000-01-0077-36	1 1/4" IPS DR 11 X 3/4" IPS DR 11	10
P000-01-0077-37	1 1/4" IPS DR 11 X 1" IPS DR 11	10



GEO-STAB® REDUCING 90 DEGREE ELLS

PART #	SIZE	PKGD.
P000-01-0077-76	1" IPS DR 11 X 3/4" IPS DR 11	10
P000-01-0077-77	1 1/4" IPS DR 11 X 3/4" IPS DR 11	10
P000-01-0077-78	1 1/4" IPS DR 11 X 1" IPS DR 11	10



GEO-STAB® REDUCING TEES

PART #	SIZE	PKGD.
P000-01-0077-82	1 1/4" IPS DR 11 X 3/4" IPS DR 11 X 3/4" IPS DR 11	10
P000-01-0077-83	1 1/4" IPS DR 11 X 1 1/4" IPS DR 11 X 3/4" IPS DR 11	10
P000-01-0077-84	1 1/4" IPS DR 11 X 1" IPS DR 11 X 1" IPS DR 11	10
P000-01-0077-85	1 1/4" IPS DR 11 X 1 1/4" IPS DR 11 X 1" IPS DR 11	10
P000-01-0077-86	2" IPS SKT X 2" IPS SKT X 3/4" IPS DR 11	10
P000-01-0077-87	2" IPS SKT X 2" IPS SKT X 1" IPS DR 11	10



GEO-STAB® MALE ADAPTER TEES

PART #	SIZE	PKGD.
P000-01-0077-90	1" MPT X 3/4" IPS DR 11 X 1/2" FPT	10
P000-01-0077-91	1" MPT X 1/2" FPT X 3/4" IPS DR 11	10
P000-01-0077-92	1/2" FPT X 3/4" IPS DR 11 X 1" MPT	10
P000-01-0077-93	1" MPT X 1" IPS DR 11 X 1/2" FPT	10
P000-01-0077-94	1" MPT X 1/2" FPT X 1" IPS DR 11	10
P000-01-0077-95	1/2" FPT X 1" IPS DR 11 X 1" MPT	10



GEO-STAB® REDUCING MALE ADAPTERS

PART #	SIZE	PKGD.
P000-01-0077-38	1" MPT X 3/4" IPS DR 11	10
P000-01-0077-39	1" MPT X 1" IPS DR 11	10
P000-01-0077-68	1" MPT X 1 1/4" IPS DR 11	10
P000-01-0077-69	1 1/4" MPT X 3/4" IPS DR 11	10
P000-01-0077-70	1 1/4" MPT X 1" IPS DR 11	10
P000-01-0077-71	1 1/4" MPT X 1 1/4" IPS DR 11	10



GEO-STAB® MALE ADAPTERS 90 DEGREE ELBOWS

PART #	SIZE	PKGD.
P000-01-0077-96	1" MPT X 3/4" IPS DR 11	10
P000-01-0077-97	1" MPT X 1" IPS DR 11	10
P000-01-0077-99	1 1/4" MPT X 1 1/4" IPS DR 11	10



CHAMFER TOOL

PART #	SIZE	PKGD.
0000-33-6580-13	3/4" IPS DR 11	1
0000-33-6580-14	1" IPS DR 11	1
0000-33-6580-10	1 1/4" IPS DR 11	1
0000-33-6580-16	1 1/2" IPS DR 11	1
0000-33-6580-17	2" IPS DR 11	1





PARALLEL HEADER



180 ALT. HEADER

3/4" PARALLEL HEADER	
PART NUMBER	DESCRIPTION INLET SIZE X NUMBER OF AND SIZE OF OUTLETS
P000-01-0078-00	1 1/4" SOCKET INLET WITH (3) 3/4" IPS DR 11 STAB OUTLETS
P000-01-0078-01	1 1/4" SOCKET INLET WITH (4) 3/4" IPS DR 11 STAB OUTLETS
P000-01-0078-10	1 1/4" SOCKET INLET WITH (5) 3/4" IPS DR 11 STAB OUTLETS
P000-01-0078-11	1 1/4" SOCKET INLET WITH (6) 3/4" IPS DR 11 STAB OUTLETS
P000-01-0078-12	1 1/4" SOCKET INLET WITH (7) 3/4" IPS DR 11 STAB OUTLETS
P000-01-0078-13	2" SOCKET INLET WITH (8) 3/4" IPS DR 11 STAB OUTLETS
P000-01-0078-14	2" SOCKET INLET WITH (9) 3/4" IPS DR 11 STAB OUTLETS
P000-01-0078-15	2" SOCKET INLET WITH (10) 3/4" IPS DR 11 STAB OUTLETS

1" PARALLEL HEADER	
PART NUMBER	DESCRIPTION INLET SIZE X NUMBER OF AND SIZE OF OUTLETS
P000-01-0078-16	1 1/4" SOCKET INLET WITH (3) 1" IPS DR 11 STAB OUTLETS
P000-01-0078-17	1 1/4" SOCKET INLET WITH (4) 1" IPS DR 11 STAB OUTLETS
P000-01-0078-18	1 1/4" SOCKET INLET WITH (5) 1" IPS DR 11 STAB OUTLETS
P000-01-0078-19	1 1/4" SOCKET INLET WITH (6) 1" IPS DR 11 STAB OUTLETS
P000-01-0078-20	1 1/4" SOCKET INLET WITH (7) 1" IPS DR 11 STAB OUTLETS
P000-01-0078-21	2" SOCKET INLET WITH (8) 1" IPS DR 11 STAB OUTLETS
P000-01-0078-22	2" SOCKET INLET WITH (9) 1" IPS DR 11 STAB OUTLETS
P000-01-0078-23	2" SOCKET INLET WITH (10) 1" IPS DR 11 STAB OUTLETS

3/4" 180 ALT. HEADER	
PART NUMBER	DESCRIPTION INLET SIZE X NUMBER OF AND SIZE OF OUTLETS
P000-01-0078-24	1 1/4" SOCKET INLET WITH (3) 3/4" IPS DR 11 STAB OUTLETS
P000-01-0078-25	1 1/4" SOCKET INLET WITH (4) 3/4" IPS DR 11 STAB OUTLETS
P000-01-0078-26	1 1/4" SOCKET INLET WITH (5) 3/4" IPS DR 11 STAB OUTLETS
P000-01-0078-27	1 1/4" SOCKET INLET WITH (6) 3/4" IPS DR 11 STAB OUTLETS
P000-01-0078-28	1 1/4" SOCKET INLET WITH (7) 3/4" IPS DR 11 STAB OUTLETS
P000-01-0078-29	2" SOCKET INLET WITH (8) 3/4" IPS DR 11 STAB OUTLETS
P000-01-0078-30	2" SOCKET INLET WITH (9) 3/4" IPS DR 11 STAB OUTLETS
P000-01-0078-31	2" SOCKET INLET WITH (10) 3/4" IPS DR 11 STAB OUTLETS

1" 180 ALT. HEADER	
PART NUMBER	DESCRIPTION INLET SIZE X NUMBER OF AND SIZE OF OUTLETS
P000-01-0078-32	1 1/4" SOCKET INLET WITH (3) 1" IPS DR 11 STAB OUTLETS
P000-01-0078-33	1 1/4" SOCKET INLET WITH (4) 1" IPS DR 11 STAB OUTLETS
P000-01-0078-34	1 1/4" SOCKET INLET WITH (5) 1" IPS DR 11 STAB OUTLETS
P000-01-0078-35	1 1/4" SOCKET INLET WITH (6) 1" IPS DR 11 STAB OUTLETS
P000-01-0078-36	1 1/4" SOCKET INLET WITH (7) 1" IPS DR 11 STAB OUTLETS
P000-01-0078-37	2" SOCKET INLET WITH (8) 1" IPS DR 11 STAB OUTLETS
P000-01-0078-38	2" SOCKET INLET WITH (9) 1" IPS DR 11 STAB OUTLETS
P000-01-0078-39	2" SOCKET INLET WITH (10) 1" IPS DR 11 STAB OUTLETS



PARALLEL HEADER

180 ALT. HEADER

3/4" PARALLEL HEADER	
PART NUMBER	DESCRIPTION INLET SIZE X NUMBER OF AND SIZE OF OUTLETS
P000-01-0078-40	1 1/4" IPS DR 11 STAB INLET WITH (3) 3/4" IPS DR 11 STAB OUTLETS
P000-01-0078-41	1 1/4" IPS DR 11 STAB INLET WITH (4) 3/4" IPS DR 11 STAB OUTLETS
P000-01-0078-42	1 1/4" IPS DR 11 STAB INLET WITH (5) 3/4" IPS DR 11 STAB OUTLETS
P000-01-0078-43	1 1/4" IPS DR 11 STAB INLET WITH (6) 3/4" IPS DR 11 STAB OUTLETS
P000-01-0078-44	1 1/4" IPS DR 11 STAB INLET WITH (7) 3/4" IPS DR 11 STAB OUTLETS

1" PARALLEL HEADER	
PART NUMBER	DESCRIPTION INLET SIZE X NUMBER OF AND SIZE OF OUTLETS
P000-01-0078-45	1 1/4" IPS DR 11 STAB INLET WITH (3) 1" IPS DR 11 STAB OUTLETS
P000-01-0078-46	1 1/4" IPS DR 11 STAB INLET WITH (4) 1" IPS DR 11 STAB OUTLETS
P000-01-0078-47	1 1/4" IPS DR 11 STAB INLET WITH (5) 1" IPS DR 11 STAB OUTLETS
P000-01-0078-48	1 1/4" IPS DR 11 STAB INLET WITH (6) 1" IPS DR 11 STAB OUTLETS
P000-01-0078-49	1 1/4" IPS DR 11 STAB INLET WITH (7) 1" IPS DR 11 STAB OUTLETS

3/4" 180 ALT. HEADER	
PART NUMBER	DESCRIPTION INLET SIZE X NUMBER OF AND SIZE OF OUTLETS
P000-01-0078-50	1 1/4" IPS DR 11 STAB INLET WITH (3) 3/4" IPS DR 11 STAB OUTLETS
P000-01-0078-51	1 1/4" IPS DR 11 STAB INLET WITH (4) 3/4" IPS DR 11 STAB OUTLETS
P000-01-0078-52	1 1/4" IPS DR 11 STAB INLET WITH (5) 3/4" IPS DR 11 STAB OUTLETS
P000-01-0078-53	1 1/4" IPS DR 11 STAB INLET WITH (6) 3/4" IPS DR 11 STAB OUTLETS
P000-01-0078-54	1 1/4" IPS DR 11 STAB INLET WITH (7) 3/4" IPS DR 11 STAB OUTLETS

1" 180 ALT. HEADER	
PART NUMBER	DESCRIPTION INLET SIZE X NUMBER OF AND SIZE OF OUTLETS
P000-01-0078-55	1 1/4" IPS DR 11 STAB INLET WITH (3) 1" IPS DR 11 STAB OUTLETS
P000-01-0078-56	1 1/4" IPS DR 11 STAB INLET WITH (4) 1" IPS DR 11 STAB OUTLETS
P000-01-0078-57	1 1/4" IPS DR 11 STAB INLET WITH (5) 1" IPS DR 11 STAB OUTLETS
P000-01-0078-58	1 1/4" IPS DR 11 STAB INLET WITH (6) 1" IPS DR 11 STAB OUTLETS
P000-01-0078-59	1 1/4" IPS DR 11 STAB INLET WITH (7) 1" IPS DR 11 STAB OUTLETS

MODEL SPECIFICATION

Stab-Type Fittings for Geothermal Applications

Scope: This specification covers requirements for mechanical connectors for polyethylene (PE) pipe for geothermal applications.

Material: All heat fused materials shall be manufactured from high density, PE3408 or PE4710 material. The PE material shall maintain a 1600 psi Hydrostatic Design Basis at 73.4 degrees F per ASTM D 2837, and shall be listed in PPI TR4 as a PE3408 or PE4710 material.

For stab type connectors, the stiffener, and PE overshoot shall be PE4710 material as described above. The shell shall be injection molded thermoplastic with a Hydrostatic Design Basis greater than or equal to 1600 psi at 73.4 degrees F per ASTM D 2837. The gripper shall be acetel. The elastomer sealing elements shall be nitrile or EPDM.

Pipe: Stab type connectors have been designed for polyethylene pipe meeting the requirements of ASTM D 3035.

Fittings: Stab type connectors shall be rated for pressure service equivalent to SDR 11 PE 3408 and PE 4710 pipe. Mechanical connectors shall be manufactured to the specifications and requirements of ASTM F 1924 Section 6.2.2.1. Mechanical connectors shall have a non-metallic internal tubular stiffener. Mechanical connectors shall not contain metallic support rings. Mechanical connectors must be designed to provide a seal on the interior surface of the polyethylene pipe.

Joints: Stab style joints shall be made in accordance with the fitting manufacturer's instructions.

Manufacturer: The fitting manufacturer shall have in place a functional quality assurance program and shall be ISO 9001 2000 certified.

Marking: Stab type connectors shall be marked with the manufacturer's name, nominal size, ASTM standard F 1924, and lot number. Mechanical connectors shall be permanently marked with a date code.

Installation: Construction and installation shall be in compliance with IGSHA Standards and all applicable local, state and federal regulations.

Hydrotesting: The completed system shall be hydrostatically tested at a pressure not greater than 150% of the pipe pressure rating. For SDR 11 PE pipe, the test pressure shall not be greater than 240 psi.

Flow coefficient: C_v values have been obtained through tests conducted by NSF in accordance with ISO/ISA S75.02-1996. For further information regarding flow coefficients, contact Continental.

Referenced Standards:

- ASTM D 3035 "*Standard Specification for Polyethylene (PE) Plastic Pipe (DR-PR) Based on Controlled Outside Diameter*"
- ASTM F 1924 "*Standard Specification for Plastic Mechanical Fittings for Use on Outside Diameter Controlled Polyethylene Gas Distribution Pipe and Tubing*"
- ASTM D 2837 "*Standard Test Method for Obtaining Hydrostatic Design Basis for Thermoplastic Pipe Materials or Pressure Design Basis for Thermoplastic Pipe Products*"
- TR-4 Plastic Pipe Institute (PPI) "*Listing of Hydrostatic Design Basis (HDB), Strength Design Basis (SDB), Pressure Design Basis (PDB) and Minimum Required Strength (MRS) Ratings for Thermoplastic Piping Materials or Pipe*"

CLOSED-LOOP/GEOTHERMAL HEAT PUMP SYSTEMS

Design and Installation Standards

The IGSHPA standards included below are updated periodically by IGSHPA. They are provided as a convenience; however, any comments and questions regarding the standards should be directed to IGSHPA. In addition, IGSHPA should be contacted for the latest version of the standards.

Forward by IGSHPA: "The Closed-Loop/Geothermal Heat Pump Systems Design and Installation Standards manual is intended as a source of precise standards and guidelines for the design and installation of Closed-Loop/Geothermal Heat Pump Systems. It is a necessary tool for product developers and manufacturers, contractors, architects, engineers, utility representatives, or anyone else concerned with proper and efficient design and installation. It was designed to be an important part of the complete set of guides and manuals available through the International Ground Source Heat Pump Association, including the *Closed-Loop/Ground Source Heat Pump Installation Guide*, *Soil and Rock Classification for the Design of Ground Coupled Heat Pump Systems Field Guide*, *Grouting Procedures for Ground Source Heat Pump Systems*, and the *Closed-Loop/Geothermal Heat Pump Systems SLINKY™ Installation Guide*."

"This manual was developed with funds from members of the International Ground Source Heat Pump Association. Through the strength of its membership, which now numbers 1200, IGSHPA has consistently played a vital leadership role in the GHP industry."

With regards to stab type mechanical fittings, reference Section 1D (1996) "Pipe Joining Methods" of the 2009 Design and Installation Standards as shown below.

1D. (1996) PIPE JOINING METHODS

- 1D.1 (2008) The only acceptable methods for joining buried polyethylene pipe systems are: 1) a heat fusion process or 2) stab-type fittings quality controlled to provide a leak-free union between pipe ends that is stronger than the pipe itself.
- 1D.2 (1997) Polyethylene pipe shall be heat fused by butt, socket, sidewall or electrofusion in accordance with the pipe manufacturer's procedures.
- 1D.3 (2008) Polyethylene fusion transition fittings with threads must be used to adapt to copper. Polyethylene fusion transition fittings with threads or barbs must be used to adapt to high strength hose. Barbed fittings utilizing mechanical clamps are not permitted to be connected directly to polyethylene pipe, with the exception of stab-type fittings as described above. All mechanical connections must be accessible.
- 1D.4 (2008) PEXa tubing may not be butt-fused or socket-fused to fittings. Polymer electrofusion fittings may be used with PEXa tubing when installed in accordance with manufacturer's published procedures. Cold-expansion compression-sleeve fittings may be used for all PEXa connections when installed according to the manufacturer's published procedures and is permitted to be direct buried with manufacturer approved corrosion covering.

For the complete 2009 Design and Installation Standards, go to the IGSHPA Web site at: www.igshpa.okstate.edu/publication/manuals.htm

GEO-STAB® ASSEMBLY INSTRUCTIONS

IMPORTANT

For use on:
Polyethylene (PE) Plastic Pipe (DR-PR) Based on Controlled Outside Diameter meeting the requirements of ASTM D 3035

Pressure Rating: 160 psig MAOP

Operating Temperature: 20° to 140° F

1 Verify the stab fitting is the correct size for the polyethylene (P.E.) pipe. Verify the SDR (or wall thickness) of the pipe matches the SDR (or wall thickness) printed on the fitting label.



2 Cut pipe ends square.



3 Clean piping thoroughly to assure there is no dirt, grease or oil in assembly area.



4 Chamfer end of pipe using [Continental's ID chamfering tool with ID gauge](#).



5 Mark the stab depth by inserting pipe into ID chamfer tool and marking the pipe at the entrance as shown.



6 If using ID chamfer tool with gauge, check for proper chamfer by inserting pipe on gauge up to the o ring. With proper chamfer, o ring will begin to enter pipe.

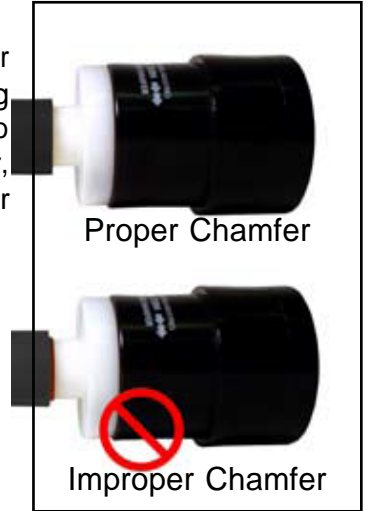

7 Stab pipe completely into fitting entrance.



8 Stab pipe completely into fitting so that the mark on the pipe is within 1/8" from the fitting entrance.



9 Repeat steps 1 thru 8 for all Geo-Stab® joints.

