

CONTRACTOR'S THERMOMETER

5" Straight or Angle

This general purpose thermometer features a red reading, non-toxic spirit-filled tube. The 5" scale is easily read against the wide front magnifying glass tubing. Rugged and economical, this industrial thermometer meets most specifications for the general construction industry. Common applications are hot-water boilers, refrigeration lines, light-duty steam service and chillers.

General Specifications

CASE: Rigid gray ABS plastic.

LENS: Glass.

SCALE: Aluminum with white finish and black markings.

Scale is V-shaped for maximum readability.

TUBE: Lens front, red spirit filled, non-toxic.

STEM: Brass.

JAM NUT: Brass.

THERMOWELL: Brass, 1/2" NPT, with 1-1/2" immersion length for pressurized systems.

ACCURACY: ±1 scale division.

AMBIENT TEMPERATURE: -40 to 140°F (-40 to 60°C).

Dimensions (in.)

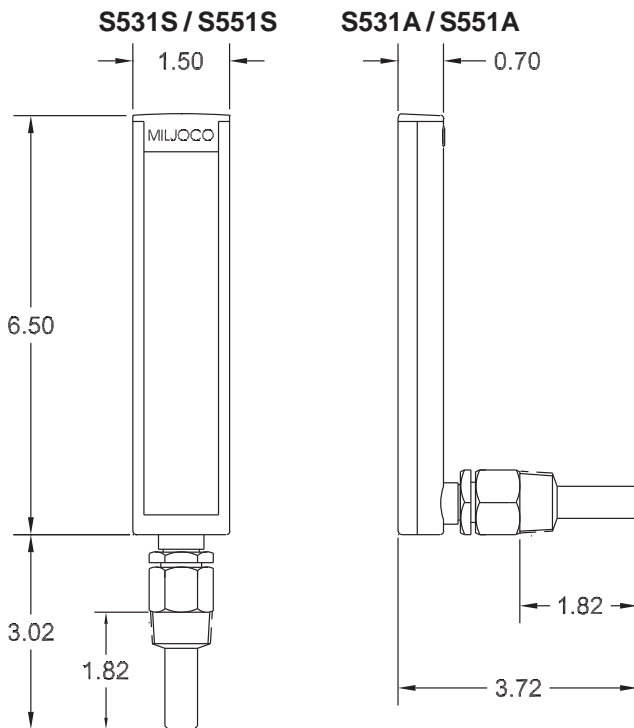

Thermowell included



S551A

Models & Ranges

Model	Style	Range	°F Scale		°C Scale	
			Fig.	Div.	Fig.	Div.
S531S	Straight	-40 to 110°F / -40 to 40°C	20°	2°	20°	2°
S551S	Straight	30 to 250°F / 0 to 115°C	50°	5°	50°	5°
S531A	Angle	-40 to 110°F / -40 to 40°C	20°	2°	20°	2°
S551A	Angle	30 to 250°F / 0 to 115°C	50°	5°	50°	5°

To Order

S551A

Model Number

